

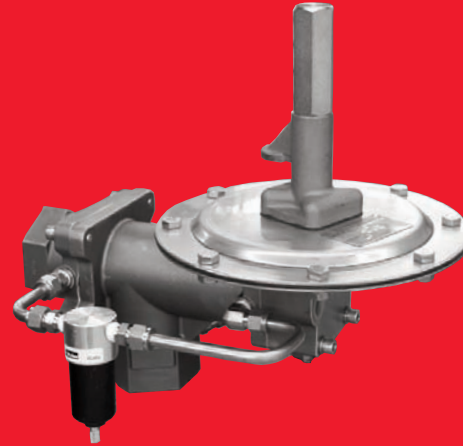

- 2" NPT inlet and outlet standard
- Pilot operated design provides tight operating band
- Optional inlet and outlet connections available
- Inlet gas pressures from 40 PSIG to 130 PSIG
- Set points from -0.5 in.W.C. to 69.2 in.W.C.
- Optional flow plates to meet specific flow requirements
- Fully field serviceable
- Optional pilot and sense line gauges
- System purge and field test capability available
- Conforms to the latest ATEX Directive



Tank Blanketing is an effective means of preventing fires in flammable liquid storage tanks by controlling the formation of explosive vapor / air mixtures. Blanketing minimizes evaporation of the stored product, thus reducing emission levels and product loss. Protection from external sources of contamination that may adversely affect the tank's contents is also provided.

The principle involved is quite simple: a blanket or pad of inert gas in the tank's vapor space prevents atmospheric air from entering the tank. The inert gas, usually Nitrogen, is injected, as necessary, into the vapor space in order to maintain a non-flammable atmosphere. The blanketing pressure is usually very low (less than 1 PSI). Outside air, which contains oxygen, moisture and other contaminants is not permitted to enter the tank. For those applications where the purity of stored product is a major concern, Protectoseal offers optional Pure-Tech cleaning and packaging specifications for the blanketing valves.

This inert gas is admitted only during inbreathing cycles (vacuum cycles). An inbreathing cycle occurs when liquid is being withdrawn from a tank, or when vapors condense in a tank due to a decrease in temperature.

The amount of inert gas required for a specific application is based on the maximum inbreathing demand under conditions of sudden cooling caused by a rain or hail-storm PLUS the maximum emptying rate.

Although Nitrogen is most commonly used for inerting, other gases, including natural gas, may be used in some applications.

Depending upon the specific application, the selection of an inert gas for a particular process is based upon one or more of the following characteristics:

1. Non-flammable in the atmosphere being protected
2. Non-contaminating
3. Chemically inactive
4. Non-toxic
5. Availability for large quantity use
6. Cost

A typical tank blanketing installation is shown in Fig. 1.

The conservation vent (A) is sized to take care of overpressure and vacuum conditions brought about by unforeseen conditions or equipment failures. The pressure setting of the vent is set at a slightly higher setting than the blanketing pressure in the tank but below the maximum pressure the tank can withstand. Similarly, the vacuum pallet is set at a higher vacuum setting than normal operating conditions bring about and below the maximum vacuum pressure the tank could withstand.

Note the placement of the flame arrester (B) to provide additional protection in the event of inert gas failure. An emergency relief vent (C) is placed on the tank, the pressure setting being slightly above the conservation vent pressure setting.

In designing a tank blanketing system, several important considerations should be evaluated:

1. Inert gas or tank blanketing equipment must be completely reliable and capable of maintaining an adequate supply of inert gas at all times. Equipment breakdown or equipment that is inadequately sized for the job will result in a higher oxygen concentration in the vapor space of the storage tank which would mix with the vapors resulting in the development of a flammable mixture.
2. The inert gas should be introduced into the tank in such a manner that it can be distributed effectively.
3. Contamination of the inert gas from any source must be guarded against. Any inerting system should have suitable devices to hold moisture and debris to an absolute minimum; such as filtration systems.

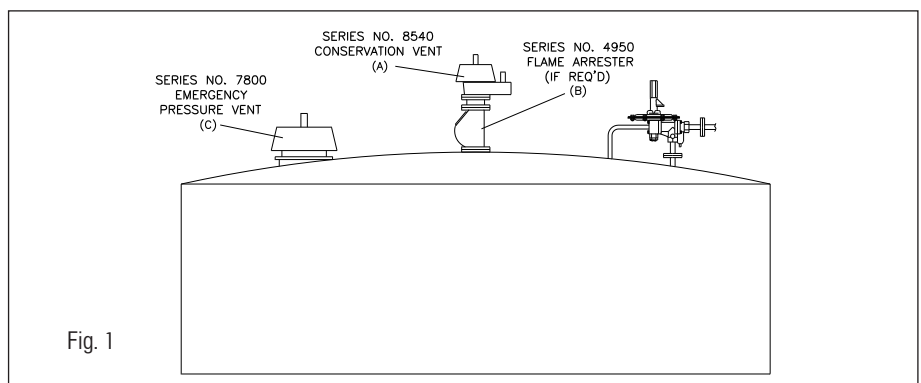

Fig. 1

PRINCIPLES OF OPERATION

A blanketing valve is used in tank blanketing applications to regulate the pressure of the inert gas layer on top of a tank's stored liquid. The valve senses the pressure of the tank blanket and opens to flow in more inert gas when pressure drops below the set pressure. The valve closes and stops flow when pressure builds back up to the set pressure. See Fig. 2 and Fig. 3.

The Protectoseal Series 10 Blanketing Valve essentially consists of two separate valves operating in tandem. The pilot valve (A), which is controlled by the sensed tank pressure, in turn controls the opening and closing of the main valve (B) which provides flow into the tank from the inert gas supply. Main components of the pilot valve are a pressure sensing chamber (C) and a poppet (D) which can move up and down. The main valve has a piston (E) which can move to control flow into the tank.

Three external connections are required for operation of the blanketing valve. One line (F) runs from the tank into the pilot valve to provide the controlling pressure. The second line (G) comes from the inert gas supply and connects to the main valve inlet. This inlet gas supply also feeds a line (H) running out through an external filter (shown as internal line for clarity) and a small orifice to bleed inert gas into the dome volume between the main and pilot valves. The third external connection (I) is the main valve outlet which provides inert gas flow into the tank.

The sensed pressure in the pilot valves comes through a remote sensing line (F) which is connected to the tank at a distance far enough from the blanketing valve connection that it will not be affected by the flow stream of inert gas into the tank. The sensed tank pressure (J), channeled to the underside of the sense diaphragm (K), pushes up while atmospheric pressure (L) and the setting spring (M) push down on the top side. When tank pressure drops below the set pressure (which is fixed by initial compression of the setting spring), then the stop (N) connected to the sense diaphragm pushes down the poppet causing the pilot valve to open.

A small fraction of an inch of movement of the poppet vacates the dome volume by allowing flow past the two seats and out of the pilot exhaust (O). This causes the piston in the main valve to open to allow gas flow into the tank. The piston is normally held closed when the dome pressure (P) equals

the inlet pressure because there is a larger area exposed to the dome pressure than to the inlet pressure. A significant drop in the dome pressure, however, allows the piston to be pushed open by the inlet pressure.

When gas flow into the tank raises tank pressure above the set pressure, the sense diaphragm is pushed up allowing the stop and the poppet to raise up (due to the spring force under the poppet) until the poppet reseals. When the poppet reseals, the dome pressure is allowed to build back up to the inlet pressure and push the piston closed again – shutting off flow to the tank.

OPERATING CHARACTERISTICS

The set pressure of the Protectoseal Series 10, Blanketing Valve is specified as the pressure at which the main valve opens.

Generally, the pilot valve will begin to leak at a pressure slightly above the set point. As the pressure moves down to the set point, the pilot opens fully causing the main valve to open. Gas flow into the tank raises the tank pressure which causes the main valve and pilot valve to reseal. The Protectoseal Blanketing Valve has a pressure-balanced poppet which provides for a consistent opening pressure over the allowable range of inlet gas supply pressures.

FEATURES & BENEFITS OF THE PROTECTOSEAL BLANKETING VALVE

- Designed specifically for tank blanketing
- Pilot-operated design provides very tight operating band
- Most compact design and fewest external connections of any pilot-operated valve on the market
- Field serviceable
- Pressure balanced pilot provides consistent opening pressure over the range of possible supply pressures
- A range of flow orifice plates provides the opportunity to tailor flow capacity to individual requirements
- A comprehensive range of materials are offered:
 - Metal parts in 316 Stainless Steel
 - Seals & gaskets in Buna-N, Neoprene, Viton®, EPDM, Chemraz® or Kalrez®
- Protectoseal Pure-Tech High Purity Blanketing Valves are available for applications involving high purity products.

NOTE: On units with Kalrez® or Chemraz® seals and gaskets, the diaphragm case gasket is Buna-N.

Viton® and Kalrez® are registered Trademarks of E.I. DuPont de Nemours & Co., Inc.

Chemraz® is a registered Trademark of Green, Tweed & Co., Inc.

MATERIALS OF CONSTRUCTION

| | | |
|---------------------------------------|--------------------|---|
| Valve Bodies & Components: | STANDARD | 316 Stainless |
| Fittings & Hardware: | STANDARD CUSTOM | 316 Stainless Others |
| Springs: | | 302 Stainless |
| Seals & Gaskets: | OPTIONS | Buna-N Neoprene, Viton®, EPDM, Chemraz®, Kalrez® & Others |
| Diaphragm: | | FEP Film |
| Filter: | OPTIONS | Aluminum / Zinc / Polypropylene / Buna-N / Acetal Stainless Steel / Polypropylene/ Viton® / Acetal |

PRIMARY OPTIONS

| | | |
|----------------------------|---------|---|
| Connections: | OPTIONS | FNPT inlet & outlet 150# or 300# welded ANSI flanges on inlet / outlet or outlet only |
| Flow Orifice Plates | OPTIONS | None (100% of maximum flow) 80%, 60%, 40%, 20% of maximum flow |
| Other Options: | | <ul style="list-style-type: none"> ■ Pressure gauges on pilot inlet and / or sense line ■ Integral purge on main and / or sense line * ■ Swing check valve between pilot inlet and main supply line ■ Field test accessories ■ Supply line filter ■ Single port sensing (see page 6) ■ Status port option (see page 6) |

**Protectoseal recommends the use of purge when tank vapors can solidify or crystallize when cooled to ambient temperatures.*

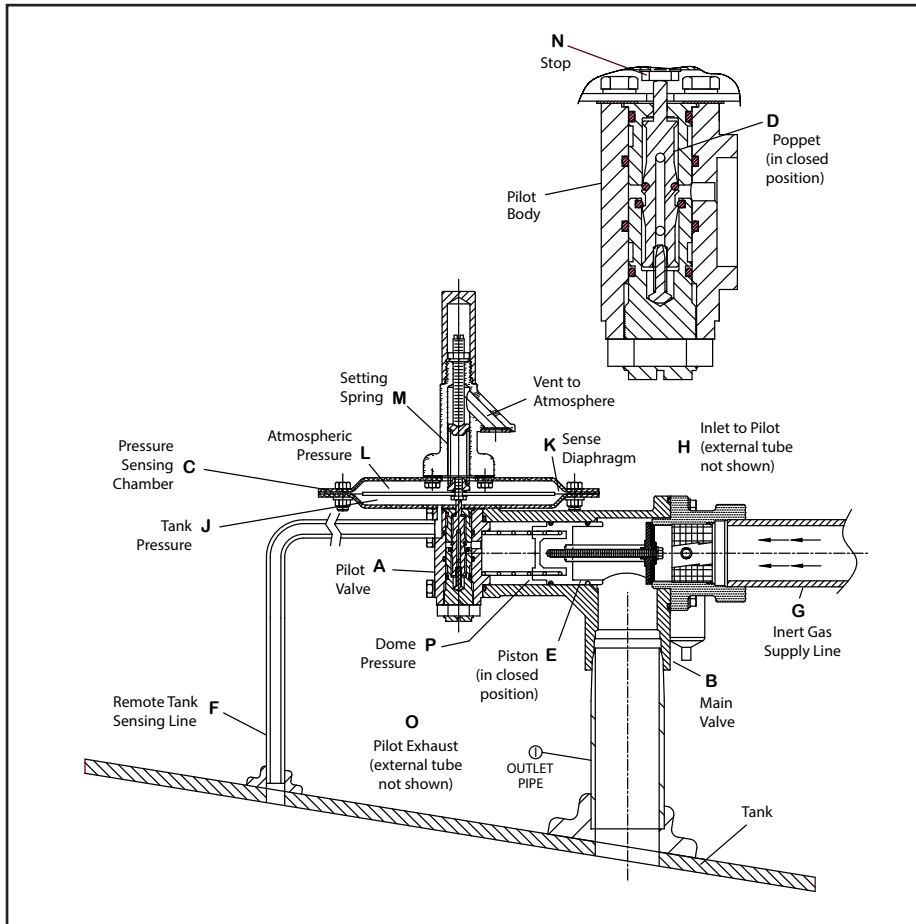

Fig. 2
 Blanketing Valve In Closed Position
 (Tank Pressure Above Set Point Pressure)

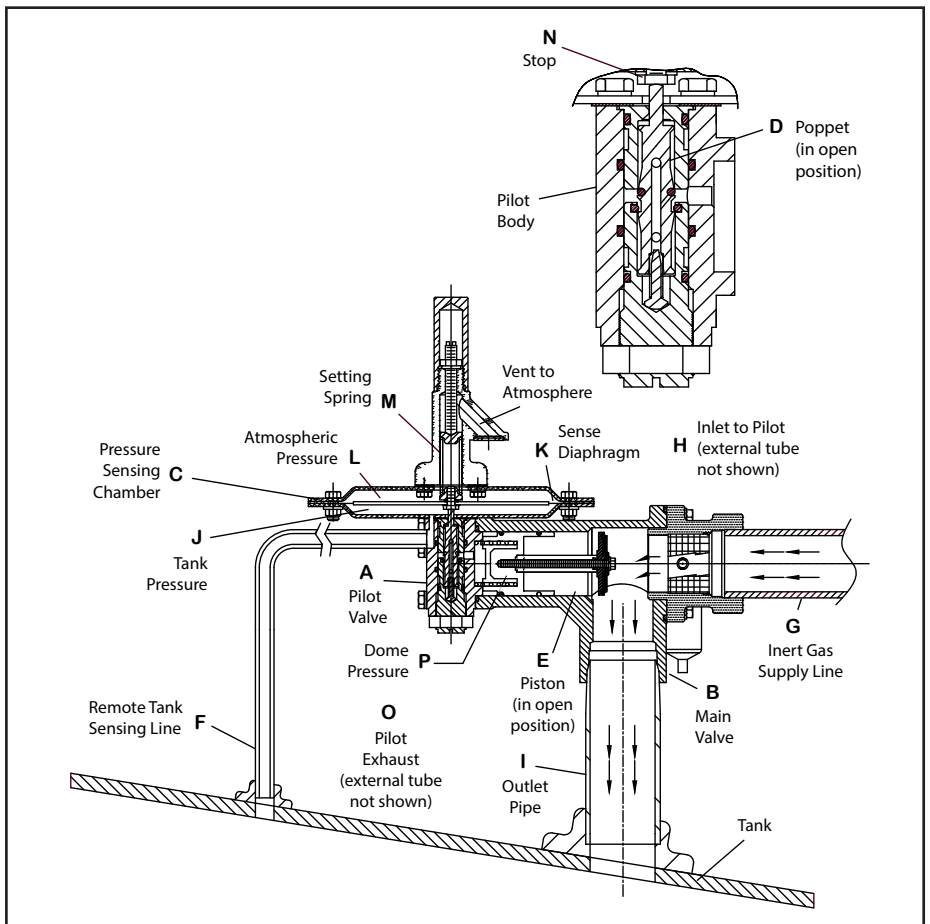

Fig. 3
 Blanketing Valve Open and Flowing
 (Tank Pressure Below Set Point Pressure)

VALVE SIZING TO MEET FLOW REQUIREMENTS

Standard API 2000 (Venting Atmospheric and Low-Pressure Storage Tanks) documents two different methods for calculating a tank's in-breathing flow requirement/blanketing valve flow requirement.

Annex A of API 2000 documents a relatively simple calculation method (see below) that may be employed, at the user's discretion, when the storage tank meets specific service conditions:

1. The tank volume is less than 30,000 m³ (180,000 bbl);
2. The maximum operating temperature of the tank's vapor space is approximately 48.9° C (120° F);
3. The tank is uninsulated;
4. The temperature of the tank's contents and feed to the tank are less than the boiling-point temperature at the maximum operating pressure of the tank.

If all the conditions are not met, it is suggested that the more comprehensive calculation method found in the Main Body of API 2000 be used for determining the in-breathing flow requirements. It is the user's responsibility to determine which method is appropriate for any new or existing tank.

The tank blanketing valve is not a substitute for the vacuum relief valve.

Annex A - Standard API 2000

Standard API 2000 (Venting Atmospheric and Low-Pressure Storage Tanks) documents the calculation methods needed to determine the blanketing valve flow requirement. Key factors are the maximum emptying rate of the tank (pumping out), and the effects of cooling due to atmospheric temperature changes. Additional factors that may be considered for a specific tank installation are also identified.

Once the flow requirements are finalized, blanketing valve sizing is accomplished by referring to the Table 3 in Step 3 on page 5. Locate the required blanketing valve flow rate. The flow listed for each supply pressure will be provided at the valve set point. Optional devices can be used to restrict flow to: 80%, 60%, 40% or 20% of the maximum flows shown.

Notes:

Please contact Protectoseal for additional assistance on sizing blanketing valves.

Tank blanketing valve failure to be taken into account when considering possible causes of overpressure in tanks. API 2000 states when the possible causes of overpressure or vacuum in a tank are being determined, other circumstances resulting from equipment failures and operating errors must be considered and evaluated by designer. Failure of the tank blanketing valve can result in unrestricted gas flow into the tank, reduced gas flow or complete loss of the gas flow.

STEP 1:

Use Table 1 below to determine the flow required to accommodate the maximum possible emptying rate.

TABLE 1 – Flow Required to Accommodate Pumping Out

| For Maximum Liquid Emptying Rate In : | To Obtain SCFH Air Required Multiply By: | To Obtain N m ³ /h Air Required Multiply By: |
|---------------------------------------|--|---|
| US gpm | 8.00 | 0.227 |
| US gph | 0.133 | 0.00379 |
| barrels/hour | 5.600 | 0.159 |
| barrels/day | 0.233 | 0.00662 |
| m ³ /h | 35.22 | 1.00 |

SCFH is at 60°F and 14.7 psia. Nm³/h is at 0°C and 101.3 kPa (absolute).

STEP 2:

Use Table 2 below to determine the flow required to accommodate the possible effects of atmospheric cooling.

TABLE 2 – Flow Required to Accommodate Thermal Effects

| Barrels | Tank Capacity | | Inbreathing Required | |
|---------|---------------|----------------|----------------------|---------------------|
| | Gallons | m ³ | SCFH | N m ³ /h |
| 60 | 2,500 | 10 | 60 | 1.7 |
| 100 | 4,200 | 16 | 100 | 2.8 |
| 500 | 21,000 | 79 | 500 | 14 |
| 1,000 | 42,000 | 159 | 1,000 | 28 |
| 2,000 | 84,000 | 318 | 2,000 | 55 |
| 3,000 | 126,000 | 477 | 3,000 | 83 |
| 4,000 | 168,000 | 636 | 4,000 | 110 |
| 5,000 | 210,000 | 795 | 5,000 | 138 |
| 10,000 | 420,000 | 1,590 | 10,000 | 276 |
| 15,000 | 630,000 | 2,385 | 15,000 | 413 |
| 20,000 | 840,000 | 3,180 | 20,000 | 551 |
| 25,000 | 1,050,000 | 3,975 | 24,000 | 661 |
| 30,000 | 1,260,000 | 4,770 | 28,000 | 772 |
| 35,000 | 1,470,000 | 5,565 | 31,000 | 854 |
| 40,000 | 1,680,000 | 6,360 | 34,000 | 937 |
| 45,000 | 1,890,000 | 7,155 | 37,000 | 1,020 |
| 50,000 | 2,100,000 | 7,950 | 40,000 | 1,102 |
| 60,000 | 2,520,000 | 9,540 | 44,000 | 1,212 |
| 70,000 | 2,940,000 | 11,130 | 48,000 | 1,323 |
| 80,000 | 3,360,000 | 12,720 | 52,000 | 1,433 |
| 90,000 | 3,780,000 | 14,310 | 56,000 | 1,543 |
| 100,000 | 4,200,000 | 15,900 | 60,000 | 1,653 |
| 120,000 | 5,040,000 | 19,080 | 68,000 | 1,874 |
| 140,000 | 5,880,000 | 22,260 | 75,000 | 2,067 |
| 160,000 | 6,720,000 | 25,440 | 82,000 | 2,260 |
| 180,000 | 7,560,000 | 28,620 | 90,000 | 2,480 |

* Interpolate between values as necessary.

STEP 3:

Add the values from Step 1 and Step 2 to determine the total flow requirement. Check the appropriate table below to the required blanketing valve flow rate. The flow listed for each supply pressure will be provided at the valve set point.

Optional orifice plates can be used to restrict flow to: 80%, 60%, 40% or 20% of the maximum flows shown;

TABLE 3: Maximum Flow through Protectoseal 2" - Series 10 Blanketing Valve

| psig | Supply Pressure | | Air | | Nitrogen | | 0.6g Natural Gas | |
|------|-----------------|------------------------|---------|---------------------|----------|---------------------|------------------|---------------------|
| | kPa (g) | kg/cm ² (g) | SCFH | N m ³ /h | SCFH | N m ³ /h | SCFH | N m ³ /h |
| 40 | 276 | 2.8 | 91,193 | 2,513 | 92,733 | 2,555 | 117,731 | 3,244 |
| 50 | 345 | 3.5 | 107,682 | 2,967 | 109,500 | 3,017 | 139,019 | 3,831 |
| 60 | 414 | 4.2 | 124,508 | 3,431 | 126,610 | 3,489 | 160,742 | 4,430 |
| 70 | 483 | 4.9 | 141,814 | 3,908 | 144,208 | 3,974 | 183,084 | 5,045 |
| 80 | 552 | 5.6 | 158,158 | 4,358 | 160,828 | 4,432 | 204,184 | 5,627 |
| 90 | 621 | 6.3 | 174,984 | 4,822 | 177,938 | 4,903 | 225,907 | 6,225 |
| 100 | 689 | 7.0 | 191,809 | 5,286 | 195,047 | 5,375 | 247,628 | 6,824 |
| 110 | 758 | 7.7 | 208,634 | 5,749 | 212,156 | 5,846 | 269,349 | 7,422 |
| 120 | 827 | 8.4 | 225,460 | 6,213 | 229,266 | 6,318 | 291,072 | 8,021 |
| 130 | 896 | 9.1 | 242,189 | 6,674 | 246,278 | 6,787 | 312,669 | 8,616 |

NOTES: Estimated flow values. Interpolate between values as necessary. SCFH is at 60° F and 14.7 psia. N m³/h is at 0° C and 101.3 kPa (absolute).

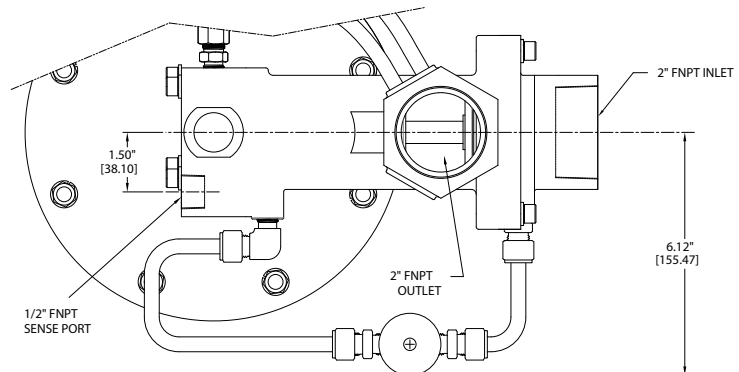
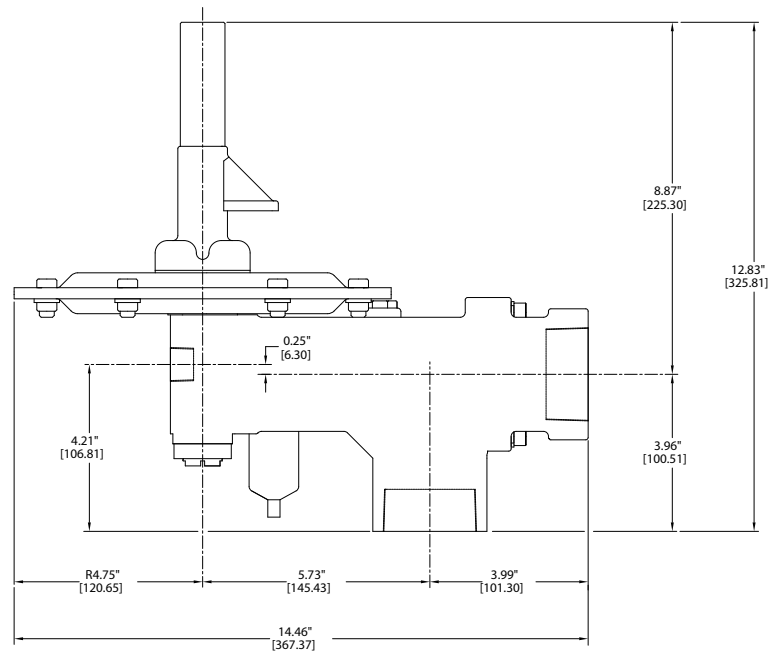

DIMENSIONS

(Dimensions shown are for reference only. Contact Factory for certified drawings.)

STATUS PORT OPTION

- Provides indication of open vs. closed valve status
- Offers remote monitoring via pressure transmitter
- Allows alarm when blanketing gas flow is excessive
- Reduces operating costs by allowing monitoring of blanketing gas usage

The Status Port Option for Protectoseal Series 10 Pilot-Operated Tank Blanketing Valves consists of a 1/4" NPT threaded port connection in the valve body. This allows the addition of a pressure transmitter (provided by other source) to provide a continuous signal to remote monitoring equipment, distributed control system, alarm system, etc. This signal indicates if the valve is open (flowing) or closed (non-flowing).

When the blanketing valve is closed, the pressure in the dome is the same as the supply pressure. When the valve is open, the pressure in the dome drops and is significantly lower than the supply pressure.

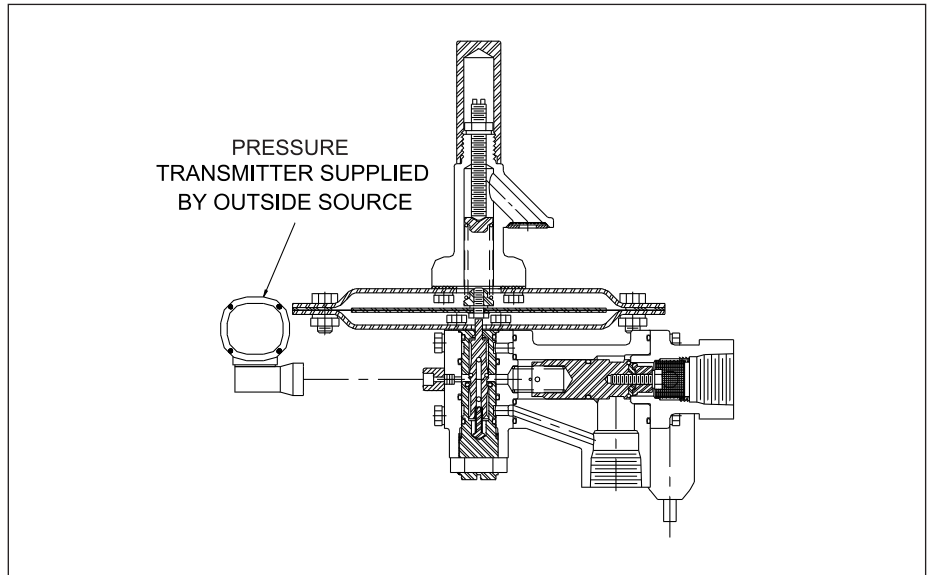

The tank's monitoring instrumentation would be calibrated to indicate an alarm condition if the open signal continues beyond a predetermined time required for tank repressurization. Action can then be taken to address the problem and preclude the loss of blanketing gas, usually Nitrogen).

Please contact the Protectoseal factory for assistance with tank blanketing valve selection and for information on Protectoseal's full range of Vapor Control Products.

SINGLE PORT SENSING

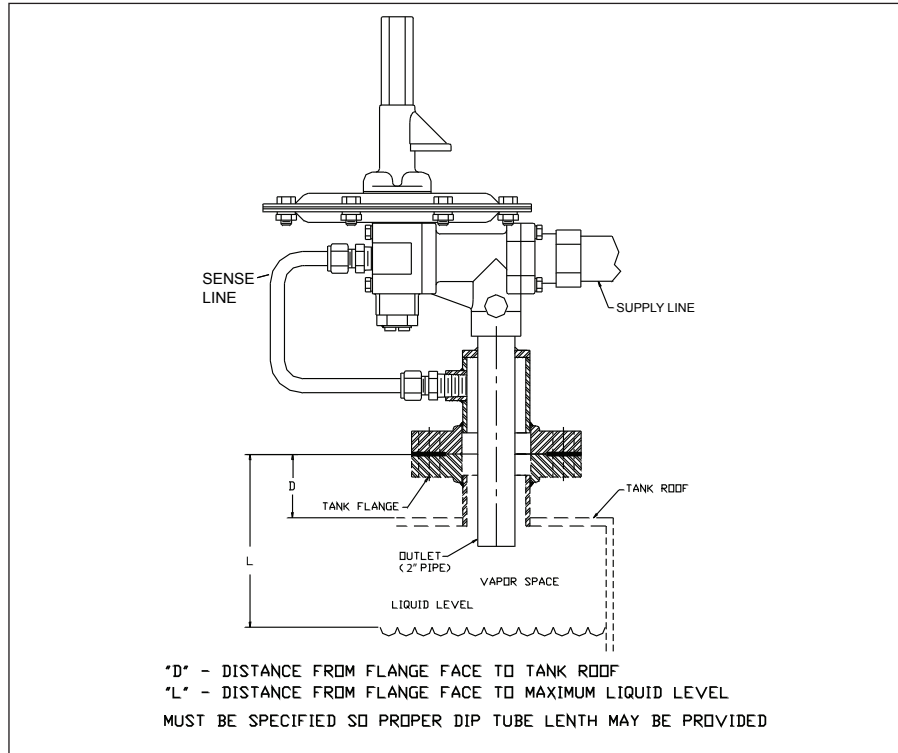

- Single connection mounting
- Eliminates need for separate sense line connection to tank
- Efficient control of tank pressure

If the preferred independent sense line configuration cannot be accommodated, the single port design allows for mounting the blanketing valve with only one tank connection. Tank vapor space pressure sensing and blanketing gas supply are accomplished through a common tank fitting. Outlet tube directs blanketing gas flow past the pressure sensing location in the connection to minimize vapor space pressure sensing errors. A minimum 1 1/2" pipe size connection is required. Consult factory for details.

Information to be Placed on the Order Form for Factory Use:

1. Part Number **2. Set Point Pressure in inches WC** **3. Supply Pressure in PSIG**

Customer: _____

Order Number: _____ Tag Number: _____

Part Number: _____ Special

Set Point Pressure¹: _____ inches WC (convert other units to inches WC for the order form)
 PSIG inches Hg mbar Other _____

Supply Pressure²: _____ PSIG (convert other units to PSIG for the order form)
 kPA kg/cm2 bar Other _____

Required Air Flow: _____ SCFH SCFM N m3/h Other _____

Elastomer Type Buna-N Neoprene Viton® EPDM Chemraz® Kalrez®
 Other _____

Inlet Connection: Pipe Size _____
 FNPT 150# Flange 300# Flange
 Other _____

Outlet Connection: Pipe Size _____
 FNPT 150# Flange 300# Flange
 Other _____

Filter: Aluminum/Zinc/Buna-N Stainless Steel 316/Viton®
 Other _____

Flow Capacity: 100% 80% 60% 40% 20%
 Other _____

Pressure Gauge: Not Included Supply Line Gauge Sense Line Gauge
 Other _____

Integral Purge: Not Included Supply Line Gauge Sense Line Gauge
 Other _____

Check Valve: Not Included Included
 Other _____

Field Test: Not Included Included
 Sense Line Shut-Off Valve
 Other _____

Options Not Listed Above: _____

¹The blanketing valve is set to OPEN at the set point pressure. If used in conjunction with pressure/vacuum vents or other relieving devices, the following guidelines should be adhered to (all values in inches WC):

| Blanketing Valve Set Point | MINIMUM Pressure Vent Set Point | MINIMUM Vacuum Vent Set Point (gauge) |
|----------------------------|---------------------------------|---|
| -0.5 to 10.0 | 2.0 ABOVE Valve Set Point | 0.5 BELOW Valve Set Point |
| 10.1 to 20.0 | 4.0 ABOVE Valve Set Point | For Blanketing Valve Set Points BELOW 0.5 gauge, set Vacuum Vent at least 0.5 gauge BELOW Valve Set Point |
| 20.1 to 30.0 | 6.0 ABOVE Valve Set Point | |
| Above 30.0 | 8.0 ABOVE Valve Set Point | |

²Supply pressure limits are 40 PSIG (276 kPa) minimum/130 PSIG (896 kPa) maximum. Production testing will be done at the given supply pressure. SET POINT RANGES MAY BE VARIED. CONTACT FACTORY FOR SPECIFIC APPLICATIONS OUTSIDE THE STATED GUIDELINES.

PROTECTOSEAL MODEL NO. 10 BLANKETING VALVE NUMBERING SYSTEM

EXAMPLE:

| | | | | | | | | | | | | | |
|-----------------------|---|---|---|---|---|---|---|---|---|----|----|----|----|
| DIGIT: | 1 | 2 | 3 | 4 | 5 | 6 | 7 | 8 | 9 | 10 | 11 | 12 | 13 |
| PART NO. CODE: | F | 1 | 0 | T | A | A | A | A | A | 0 | 0 | 0 | 0 |

| | | | | | |
|-----|---|---|----|--|---|
| 1 | MATERIAL | F: 316 Stainless Steel K: Same as above with cleaning/packaging to Pure-Tech specifications | 8 | FLOW CAPACITY REDUCTION ORIFICE PLATE | A: 100% (NO REDUCTION) B: 80% C: 60% D: 40% E: 20% |
| 2-3 | SERIES NO. | 10 2" Blanketing Valve | 9 | PILOT FILTER OPTION** | A: Aluminum/Zinc B: 316 Stainless Steel |
| 4 | REVISION LEVEL | T | 10 | CHECK VALVE OPTION | 0: Not Included 1: Included |
| 5 | CONNECTIONS: (INLET / OUTLET) | A: 2" FNPT / FNPT B: 2" FNPT / 150# flange C: 2" FNPT / 300# flange D: 2" 150# flange / 150# flange E: 2" 300# flange / 300# flange F: DN 50 / DN 50 (PN16) G: DN 50 / DN 50 (PN10) H: 3" FNPT / FNPT I: 3" FNPT / 150# RF flange J: 3" FNPT / 300# RF flange K: 3" 150# RF flange / 150# RF flange L: 3" 300# RF flange / 300# RF flange M: DN 80 / DN 80 (PN 16) N: DN 80 / DN 80 (PN10) | 11 | PRESSURE GAUGE OPTION*** | 0: No gauges 1: Supply line gauge only 2: Sense line gauge only 3: Sense line & supply line gauges |
| 6 | SET POINT PRESSURE RANGE (in inches WC) | A: 0.0" & including 2.0" B: Above 2.0" & including 5.0" C: Above 5.0" & including 15.0" D: Above 15.0" & including 50.0" E: Above 50.0" & including 69.2" F: -0.5" up to but not incl. -0.1" | 12 | INTEGRAL PURGE OPTION (See Note below) | 0: No purge 1: Outlet line purge only 2: Sense line purge only 3: Outlet line and sense line purge |
| 7 | MATERIALS SEALS & GASKETS* | A: Buna-N B: Neoprene C: Viton® D: EPDM E: Kalrez® F: Chemraz® | 13 | FIELD TEST OPTION **** | 0: Not included 1: Included 2: Included with 3-way valve for sense line |

NOTE: Protectoseal recommends the use of purge when tank vapors can solidify or crystalize when cooled to ambient temperatures.

* On units with Kalrez® or Chemraz® seals and gaskets, the diaphragm case gasket will be Buna-N.
 ** Supply line filters available (sold separately - consult factory).
 *** Stainless steel gauge available (consult factory).
 **** Sense line and supply line gauges included. Digit #11 should be option 3.

Viton® and Kalrez® are registered Trademarks of E.I. DuPont de Nemours & Co., Inc.
 Chemraz® is a registered Trademark of Green, Tweed & Co., Inc.



225 Foster Ave., Bensenville, IL 60106-1690
 P 630.595.0800 F 630.595.8059
 info@protectoseal.com www.protectoseal.com