

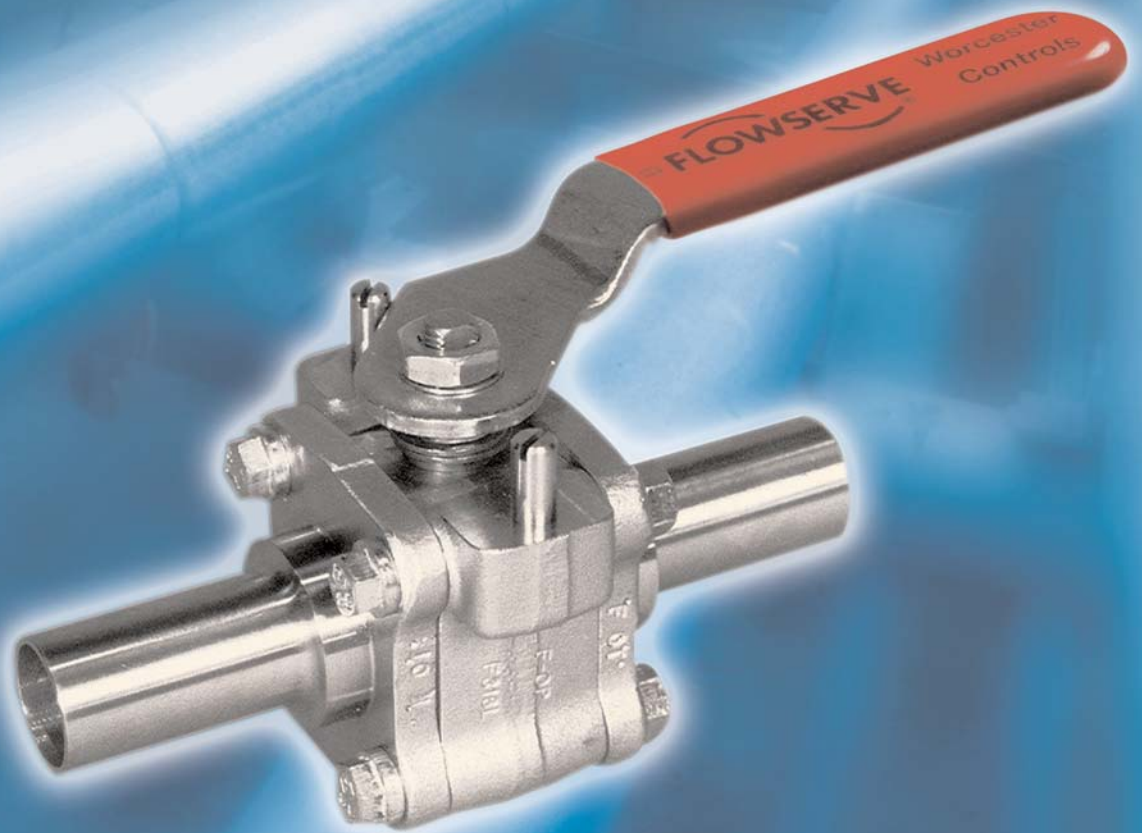

***Series WK 70/74  
Low Ferrite Tube Bore Clean Valves***



***Experience In Motion***

Flowserve Worcester Controls' Series WK 70 forged clean valves and WK 74 cast clean valves operate dependably in the pharmaceutical, biotech, food, cosmetic, paint, chemical and semi-conductor manufacturing industries where microbes, media deposits, mineral impurities and cross-contamination can threaten the quality of the product. The high-purity design, high vacuum rating, high cycle life and pressure/temperature rating of these valves makes them ideal for applications from sterile steam to nutrient inlets to high-purity water. The performance of these tube bore clean valves is based on a combination of high standard specifications.

## WK 70 Forged-Tube Bore and WK 74 Cast-Tube Bore

A clean valve to write your specifications around:

Bore, metallurgy, surface finish, shut-off, automation and ease of cleaning

### ● Tube Bore

The inside diameter of the valve components are tube bore dimensions so that the valve precisely matches the tubing it is connected to. This prevents buildup of pyrogens or bacteria.

### ● Forged Valve

WK 70 valves are built of forged parts. From an integrity perspective, forgings are better than castings for clean service because they are stronger, free from crevices, pits, shrinks or inclusions and have better controlled metallurgy.

### ● Low Ferrite Content

WK 70 valves are made of 316L stainless steel and have a guaranteed ferrite content of less than 1%. The WK 74 is cast from CF3M (316L) and has a guaranteed ferrite content of less than 5%. This prevents rouging resulting from minerals and impurities drawn from higher ferrite content metals.

### ● High Integrity Welds

The metallurgy of the body and extended tube ends assures the integrity of the orbital welding. The tube ends have a verifiable sulphur content between .005 percent and .016 percent. Too much sulphur causes a lack of penetration of the orbital welding. With a low sulphur content comparable to that of the process tubing, the quality of the weld is assured.

### ● CMTRs

Certified Material Test Reports are available for the body, pipe ends, ball and stem (request when placing order).

### ● High-Cycle Sealing, Bubble-Tight Shutoff

Seats of PTFE, Reinforced PTFE or Fluorofill provide bubble-tight shutoff through the valve, even under conditions of high vacuum and high cycle operation. High-cycle stem seals assure external sealing when the valve is automated.

### ● Steam Service Capability

Fluorofill is a PTFE material with carbon and graphite fillers with excellent high temperature properties. These standard seats are capable of up to 20 barg working steam pressure (WSP) making the WK 70 valve ideal for sterile steam applications.

### ● 3"- 4" Series WK 70 Clean Valves

Worcester's clean valves are optionally available in 3" and 4" sizes with quick disconnecting Hygienic Clamps and XBO (Automatic Tube Butt weld) ends.

### ● Purge Ports

Purge ports are available for CIP (Clean in Place) & SIP (Sterilise in Place) applications.

## WK 70 Forged-Tube Bore and WK 74 Cast-Tube Bore

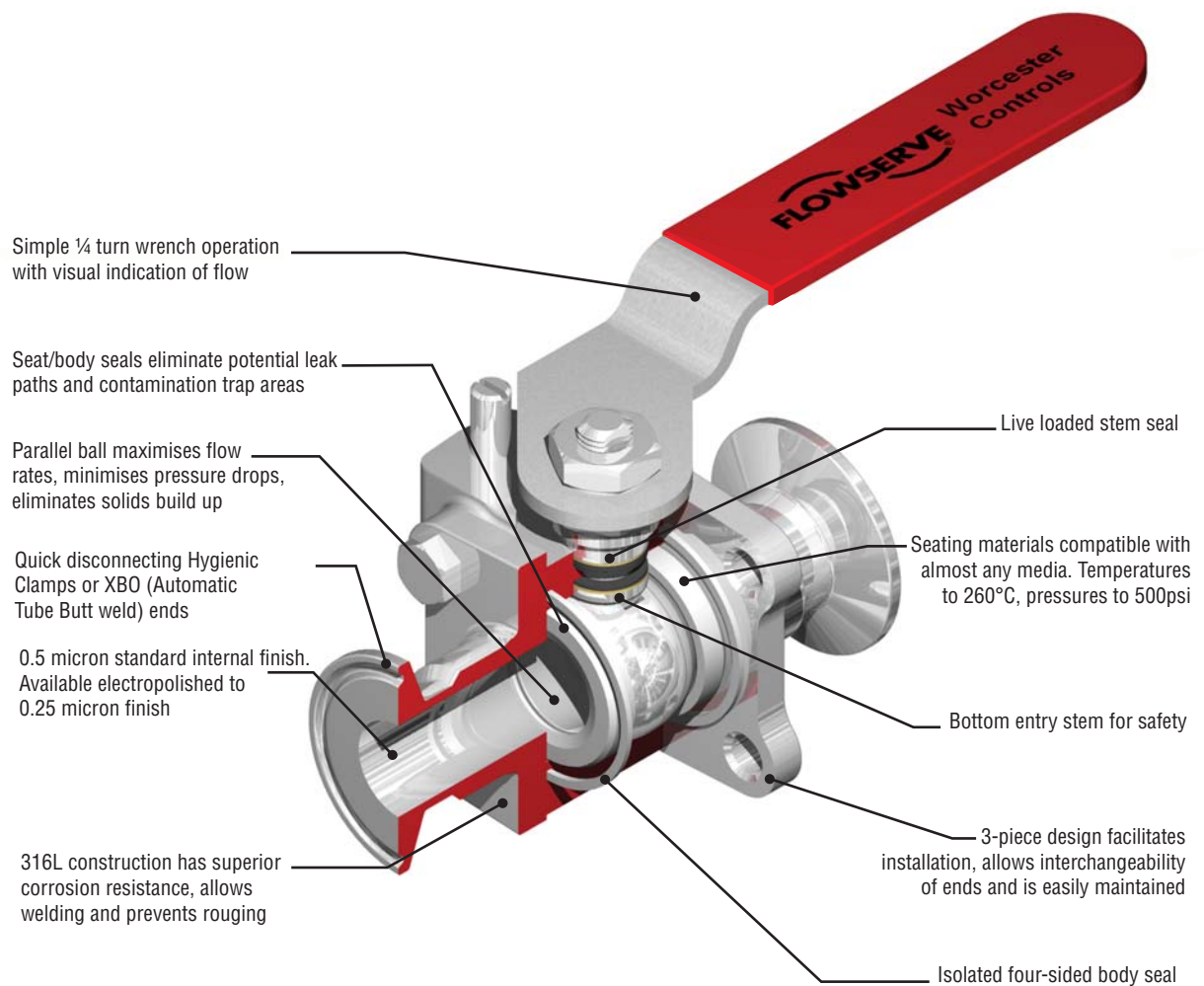

## WK 70 Forged-Tube Bore and WK 74 Cast-Tube Bore Parts / Materials List

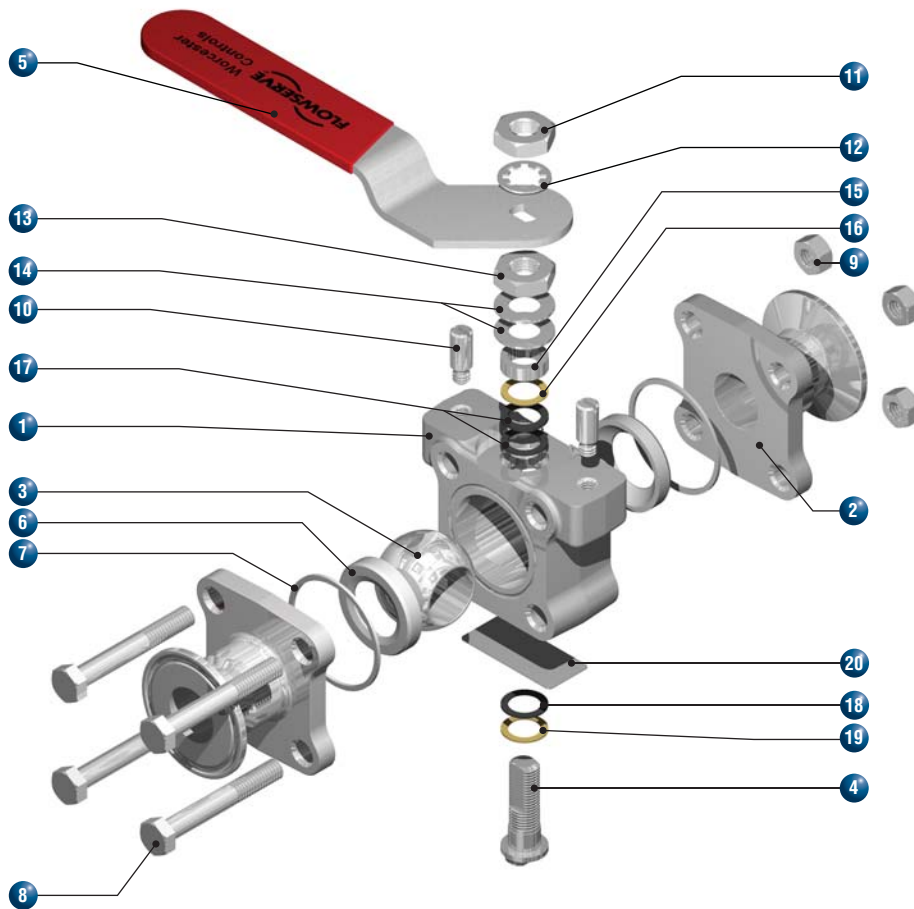

No.	Description	WK 70 Forged-Tube Bore	WK 74 Cast-Tube Bore	No.	Description	WK 70 Forged-Tube Bore	WK 74 Cast-Tube Bore
1	Body	Stainless Steel ASTM A182-F316L	Stainless Steel ASTM A351 CF3M	11	Wrench Nut	Stainless Steel AISI 300, Series Zinc-Plated	Stainless Steel AISI 300 Series Zinc-Plated
2	Pipe Ends	Stainless Steel ASTM A182-F316L	Stainless Steel ASTM A351 CF3M	12	Lockwasher	Stainless Steel AISI 300 Series	Stainless Steel AISI 300 Series
3	Ball	Stainless Steel A479-316L	Stainless Steel A479-316L	13	Gland Nut	Stainless Steel AISI 300 Series Zinc-Plated	Stainless Steel AISI 300 Series Zinc-Plated
4	Stem	Stainless Steel A479-316L	Stainless Steel A479-316L	14	Belleville Washers	Stainless Steel AISI 301	Stainless Steel AISI 301
5	Wrench	Stainless Steel, Plastinol dipped sleeve	Stainless Steel, Plastinol dipped sleeve	15	Follower	Stainless Steel AISI 316L	Stainless Steel AISI 316L
6	Seat	PTFE-Virgin / PTFE-Reinforced / Polyfill / TFM-virgin	PTFE-Virgin / PTFE-Reinforced / Polyfill / TFM-Virgin	16	Seal Protector	PEEK	PEEK
7	Body Seals	PTFE-Virgin	PTFE-Virgin	17	Stem Seals	PTFE-Virgin / Polyfill / TFM-Virgin	PTFE-Virgin / Polyfill / TFM-Virgin
8	Body Bolts	Stainless Steel ASTM F593-316 GR.2	Stainless Steel ASTM F593-316 GR.2	18	Thrust Bearing	PTFE-Virgin / Polyfill / TFM-Virgin	PTFE-Virgin / Polyfill / TFM-Virgin
9	Body Nuts	Stainless Steel ASTM A194 GR.8	Stainless Steel ASTM A194 GR.8	19	Thrust bearing	PEEK	PEEK
10	Stop Pin	Stainless Steel A276-300 Series	Stainless Steel A276-300 Series	20	ID Plate	Stainless Steel	Stainless Steel

## WK 70 Forged-Tube Bore and WK 74 Cast-Tube Bore

4 BOLT FIXING (DN40 & 50)  
ISO 5211 MOUNTING PATTERN  
(SEE DIMENSION CHART)

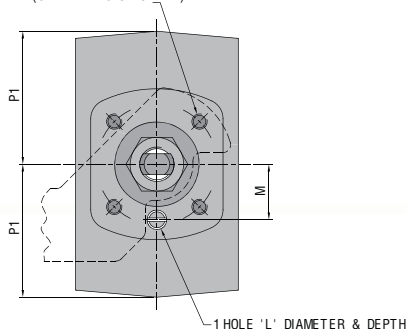

2 HOLES 'L' DIAMETER & DEPTH

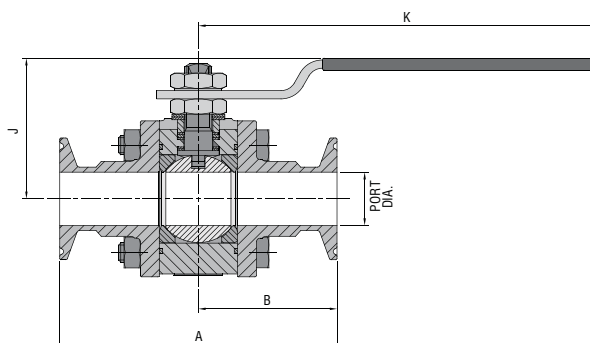
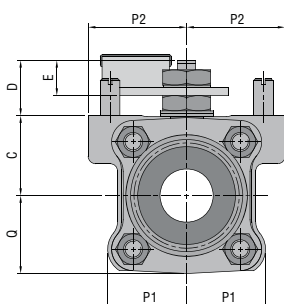
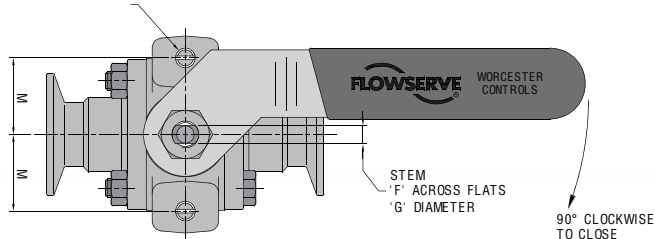

### Dimensions (mm)

DN	Port Min Ø	A	B	C	D	E	F A/F	G THREAD	J	K	L	M	P1	P2	Q	ISO	Mounting Holes	Platform Recess	Weight Kg
½"	9.3	89.7 88.0	44.4	24.33 23.32	16.66 14.35	13.21 10.97	0.217 0.213	3/8-24 UNF	44.1	140.5	1/4-20 UNC 9.1 MIN	24.0	23.8	29.6	22.8	NA	NA	NA	0.5
¾"	16.6	102.3 100.6	50.7	27.69 26.67	16.66 14.33	13.21 10.97	0.217 0.213	3/8-24 UNF	47.5	140.5	1/4-20 UNC 9.1 MIN	27.0	27.2	33.3	25.8	NA	NA	NA	0.8
1"	22.0	115.8 114.1	57.5	33.60 32.59	24.08 21.77	15.70 13.49	0.296 0.292	7/16-20 UNF	58.3	165.9	1/4-20 UNC 9.1 MIN	31.75	32.7	40.8	31.1	NA	NA	NA	1.4
1½"	34.7	142.1 140.4	70.6	46.33 45.34	29.77 27.48	19.66 17.35	0.343 0.339	9/16-18 UNF	73.6	204.0	1/4-20 UNC 9.1 MIN	23.0	44.3	NA	41.9	F05	4 OFF 1/4-20 UNC 9.1 DEEP MIN ON 50.0 PCD	Ø 35.59/34.57 0.139/0.129 DEEP	2.8
2"	47.4	170.7 169.0	84.9	55.78 54.79	29.77 27.48	19.66 17.35	0.343 0.339	9/16-18 UNF	83.0	204.0	1/4-20 UNC 9.1 MIN	23.0	51.9	NA	51.9	F05	4 OFF 1/4-20 UNC 9.1 DEEP MIN ON 50.0 PCD	Ø 35.59/34.57 0.139/0.129 DEEP	4.3

N.B. 3" and 4" valves available as WK74 cast tube bore only, dimensional details upon request.

## Applications

### Microelectronics Manufacturing

- High vacuum
- High-purity gases
- Toxic gases
- Solvent lines
- Instrumentation tie-ins

### Pharmaceutical/Biotech

- High-purity water
- Sterile steam
- Flush-bottom tank valves
- Cleaning: acids, caustic, deionised water
- Gas and air sparging
- Media and nutrients inlets

### Sterile steam/Distillation

- Sterile steam
- Distilled water
- Recirculation loops

### Cosmetics and Creams

- Oils
- Shampoos, detergents
- White wax

### Lyophilisation (Freeze-Drying)

- High vacuum
- Cryogenic liquids
- Super-cooled oils
- Sterile steam
- High-purity inert gases

### Food Processing

- Wine and spirits
- Hot cooking oils
- Steam
- Water feed lines
- Retort lines

## Environment Control

Worcester Controls assembles all clean service and cryogenic valves in a Class 100 work area.

### Testing and Inspections

#### U.V Light Test

All wetted components are U.V. light inspected to confirm that all surfaces are free of fluorescent oils or greases.

#### Wipe Test

All wetted components are then wipe tested using Whatman #44 paper, to ensure all surfaces are free of grit, dirt and contamination.

#### Helium Leak Test

Once assembled, all valves are pressurised internally with 80 psi of helium. They are then mass spectrometer tested for both through and external leaks. No leakage is permitted.

#### Vacuum Sealed

After all testing has been completed, clean valves are double vacuum-sealed in 4 mil plastic bags that are nested one inside the other. This ensures product integrity up to the point of delivery.

## Surface Finish Measurements

RMS (microinch)	RMS (micron)	Ra (micrometre)	Grit Size
160	4.06	3.50	36
98	2.49	2.18	60
80	2.03	1.78	80
58	1.47	1.30	120
34	.86	0.75	180
17	.43	0.38	240
14	.36	0.30	320



## Valves For Stick-Free Operation on Rubber Polymers, Monomers, Styrene, Butadiene, Slurries

### Cavity Filler

Worcester Controls offers the quality solution to sticking valve problems - cavity-filled ball valves. Some of the roughest process control problems involve those in butadiene and styrene services. These and other fluids such as rubber polymers can polymerize in place. That means they can polymerise inside valve body cavities, effectively immobilising the valves.

In applications where product can polymerize, FEP seats are available to reduce "blooming" which can occur in PTFE or reinforced PTFE seats.

A unique seat design using PTFE, Fluorofill or FEP eliminates most of the volume between the ball, stem and body. This reduces area for product build-up associated with conventional ball valves.

### Fire Safety

Worcester Controls offers a fire-rated version of the cavity-filled valve. FEP cavity filled seats are qualified per API 607(4th Edition). Grafoil stem seals and body seals (suitable for butadiene processes) are used on fire-rated valves.

### Automation

Cavity-filled valves may be completely automated with Norbro 40R series pneumatic or 75 series electric actuators. Both actuators can be optionally equipped with process monitoring equipment and/or positioners for modulating applications. Special automation packages are available for PLC/computer-controlled systems.

The Automax SXL Series utilises a 316 series stainless steel body and is ideal for use in corrosive environments. It is available in both Double Acting and Spring Return versions with a maximum double acting torque output of 822.4Nm. The SX Series can be supplied with stainless steel or aluminium pistons and springs per customer requirements and is also available with optional polished finishes for sanitary applications.

### Applications:

- Styrene
- Monomers
- Butadiene
- Detergent Slurry
- Fermentation Process
- Food Process
- Pharmaceuticals
- Fire-Safe Applications

## Seat Pressure / Temperature Ratings for WK70 and WK 74

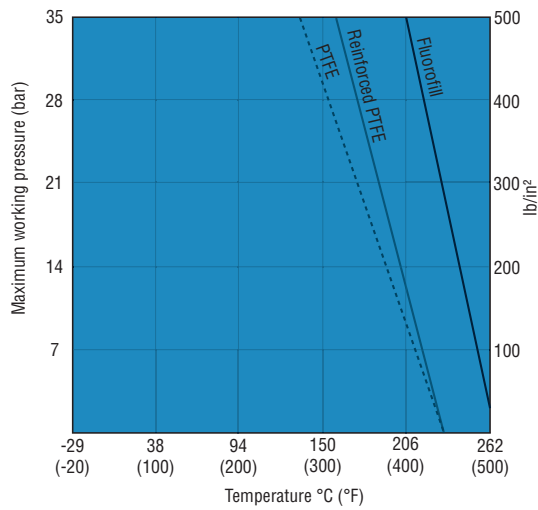

### NOTE:

Stainless steel valves are CE Marked in accordance with the Pressure Equipment Directive 97/23/EC, conformity assessment Module H and are classified in Category III (not end of line duty).

Carbon steel valves are classified as SEP (Sound Engineering Practice) and, in accordance with the Pressure Equipment Directive, are not CE Marked. These valves may be used within the limitations defined in Annex II of the Directive.

## End Connections WK70 & WK74



Standard end connections for tubing are quick disconnecting Hygienic Clamps and Extended Butt Weld (XBO Automatic Tube Butt weld) ends for use with orbital welders. Service pressure ratings of Quick Disconnect ends vary according to the type of clamp fittings and gaskets used (consult Flowserve). XBO ends are rated to 800 psi with one-piece seats, and 1500 psi if using separate seats and seals. Valves with end connections compatible with compression fittings are available - please contact Flowserve.

### C<sub>v</sub> Values and Equivalent Length of .065" tubing WK70

Valve Size	TC		XBO		Equivalent Length Tubing. mm	
	C <sub>v</sub>	K <sub>v</sub>	C <sub>v</sub>	K <sub>v</sub>	Quick Disconnect	XBO
½"	8.1	7	6.5	5.6	88.9	141
¾"	28.6	24.76	24.3	21	102	147
1"	67	58	56.4	48.8	115	162
1½"	192	166	165	142.8	142	191
2"	434	375.8	402	348	170	204

### C<sub>v</sub> Values and Equivalent Length of .065" tubing WK74

Valve Size	TC		XBO		Equivalent Length Tubing. mm	
	C <sub>v</sub>	K <sub>v</sub>	C <sub>v</sub>	K <sub>v</sub>	Quick Disconnect	XBO
½"	8.1	7	6.5	5.6	88.9	141
¾"	28.6	24.76	24.3	21	102	147
1"	67	58	56.4	48.8	115	162
1½"	192	166	165	142.8	142	191
2"	434	375.8	402	348	170	204

To find your local Flowserve representative:

For more information about Flowserve Corporation, visit [www.flowserve.com](http://www.flowserve.com)

WCEBR0026-01 Printed in Germany.

Due to continuous development of our product range, we reserve the right to alter the dimensions and information contained in this leaflet as required. Information given in this leaflet is made in good faith and based upon specific testing but does not, however, constitute a guarantee.



### Flowserve Flow Control

A Division of Flowserve GB Ltd  
Burrell Road, Haywards Heath  
West Sussex RH16 1TL  
United Kingdom  
Telephone: +44 (0)1444 314400  
Telefax: +44 (0)1444 314401  
Email: [wvukinfo@flowserve.com](mailto:wvukinfo@flowserve.com)